

Montageanleitung

Eckschrank-Schwenkauszug
LeMans (mit fester Achse)

Mounting Instructions

Full Swing Corner Pull-out
(with fixed axle)

Notice de montage

Système pivotant "LeMans" pour
meuble d'angle
(avec axe fixe)

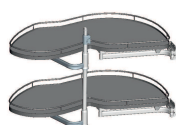
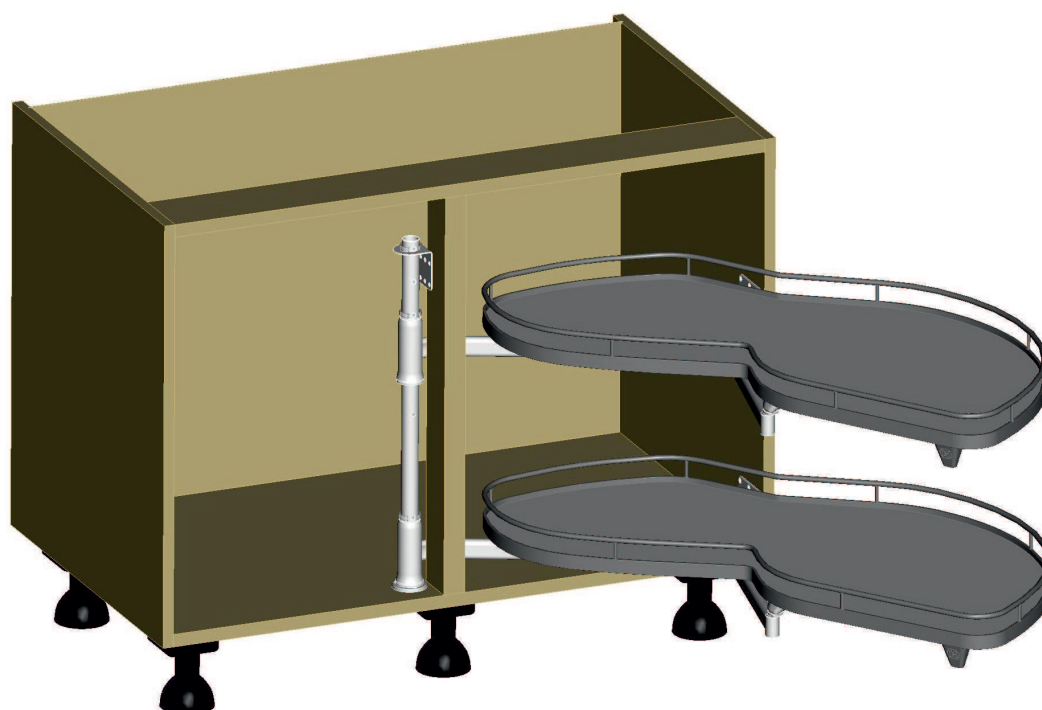

+ = max 40 kg



Eigengewicht + Beladung
Empty weight + Load
Poids + Chargement



SYMBOLE • SYMBOLS • SYMBOLES • SYMBOLI • SIMBOLOS • SIMBOLOS • MERKIT • SYMBOLER • SYMBOLY • SYMBOLE •



Warnung! • Warning! • Avertissement! • Avvertenza! • ¡Advertencia! • Aviso! • Varoitus! • Advarsel! • Výstraha! • Ostrzezenie! •



Nicht korrekt! • Incorrect! • Incorrect! • Non corretto! • ¡Incorrecto! • Incorrecto! • Väärin! • Ikke korrekt! • Nesprávně! • Nieprawidłowo!



Korrekt! • Correct! • Correct! • corretto! • ¡Correcto! • Correcto! • Oikein! • Korrekt! • Správně! • Prawidłowo!!



Fixieren/fixiert! • Secure/Secured! • Fixer/fixé • Fissare/fissato! • ¡Fijar/fijado! • Fixar/fixo! • Kiinnitä/kiinnitetty! • Spænde/sændt •



Lösen/gelöst! • Release/Released! • Détacher/détaché • Allentare/allentato! • ¡Soltar/suelto! • Soltar/solto! • Irroita/irroitettu! • Løsne/løsnet • Povolit/povolento! • Zwolnic/zwolnione!



Keinen Akkuschauber verwenden! • Do not use a cordless screwdriver! • Ne pas utiliser de tournevis à piles • Non utilizzare un avvitatore a batteria! • ¡No utilizar tladro atornillador! • Não usar aparafusadora sem fio! • Älä käyttää akkuruuvinväännintä! • Brug ikke batteriskruetrækker! • Nepouzivejte akušroubovák! • Nie używac wkrtarki akumultorowej! •



PZ2-Schraubendreher verwenden! • Use a PZ2 screwdriver! • Utiliser un tournevis Pz2 • Usare il cacciavite Pz2! • ¡Utilizar un destornillador Pz2! • Usar chave de parafusos Pz2! • Käytä PZ2-ruuviataltaa! • Brug PZ2-skrueetrækker! • Pouzijte krizový šroubovák Pz2! • Użyc wkretaka Pz2!



Optionales Element! • Optional element! • Élément optionnel! • Elemento opzionale! • ¡Elemento opcional! • Elemento opcional! • Valinnainen elementti! • Valgfrit element! • Voltitelný prvek! • Element opcjonalny! •



Klick-Geräusch beim Einrasten! • Audible click on engagement! • <<Clic>> lors de l'encliquetage • Quando si innesta si sente un clic! • ¡Ciaondo encaja se oye un clic! • Ruído de clique ao engatar! • Lukittuessa kuuluu klik-ääni! • Klikyd ved monterging! • Slyšitelné zacvaknutí! • Trzask przy zaskakiwaniu! •



Alle Maße in mm! • All dimensions in mm! • Toutes les dimensions en mm! • Tutte le dimensioni in mm! • ¡Todas las medidas son en mm! • Todas as medidas em mm! • Kaikki mitat mm! • Alle mal er mm! • Vsechny rozmery v mm! • Wszystkie wymiary w mm! •

Die technische Darstellung und Maßangaben -auch bei Abbildungen und Zeichnungen - sind unverbindlich. Konstruktionsverbesserungen sind vorbehalten! • Technical information and stated dimensions (including in illustrations and drawings) must not be regarded as binding. Design subject to change without notice (in interest of improvement)! • Les illustrations techniques et les cotes y compris sur les schémas et les dessins sont non contractuelles. Sous réserve d'améliorations de la construction! • Le rappresentazioni tecniche e le indicazioni delle dimensioni anche nelle figure e nei disegni non sono vincolanti. Con riserva di miglioramenti di progettazione! • Las descripciones técnicas y los datos dimensionales, inclusive los incluidos en fotos y figuras, son meramente orientativos y no vinculantes. ¡Reservado el derecho a mejoras constructivas! • As descrições técnicas e as indicações de medidas também em ilustrações e desenhos não são de natureza imperativa. Salvo melhoramentos de construção! • Tekniset piirrokset ja mitat myös kuvissa ja piirroksissa olevat ovat sitoumuksetta. Oikeus teknisiin parannuksiin pidätetään! • De tekniske fremstillinger og måleangivelser også i figurer og tegninger er vejledende. Forbehold for konstruktionsforbedringer! • Technické znázornění a rozměry i na obrázcích a výkresech jsou nezávazné. Konstrukční změny vyhrazeny! • Prezentacje techniczne i dane wymiarowe także na rysunkach są niewiązace. Zmiany konstrukcyjne zastrzeżone! •

1

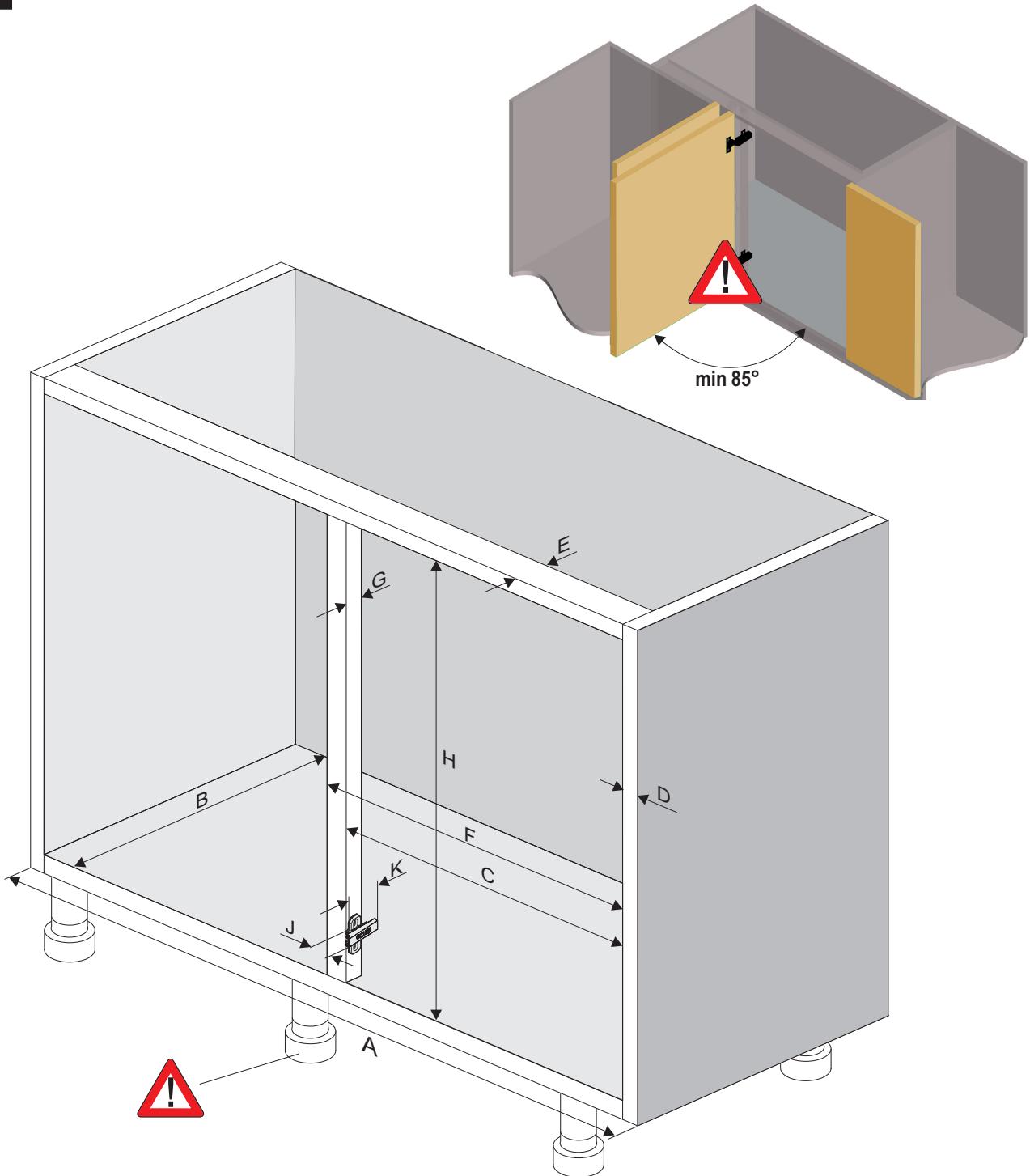

Maß mm	A	B	C	D	E	F	G	H			J	K
45er	min. 900	min. 500	411 - 418	16 - 19	min. 45	max. 450	max. 65	Achse	006919	min. 535	max. 25	max. 70
								axle	006930	min. 655		
50er	min. 1000	min. 500	461 - 468	16 - 19	min. 45	max. 500	max. 65	Achse	006919	min. 535	max. 25	max. 70
								axle	006930	min. 655		
60er	min. 1000	min. 500	561 - 568	16 - 19	min. 45	max. 600	max. 65	Achse	006919	min. 535	max. 25	max. 70
								axle	006930	min. 655		

2

1. Anschraubpositionen festlegen *Locate bolting positions*

Euroschrauben mit Senkkopf und Doppelganggewinde 6,3 x 15 verwenden
 Empfohlenes Anzugsmoment: 3,1 Nm
*Use Euro screws with countersunk head and double-start thread 6,3 x 15
 Recommended torque: 3,1 Nm*

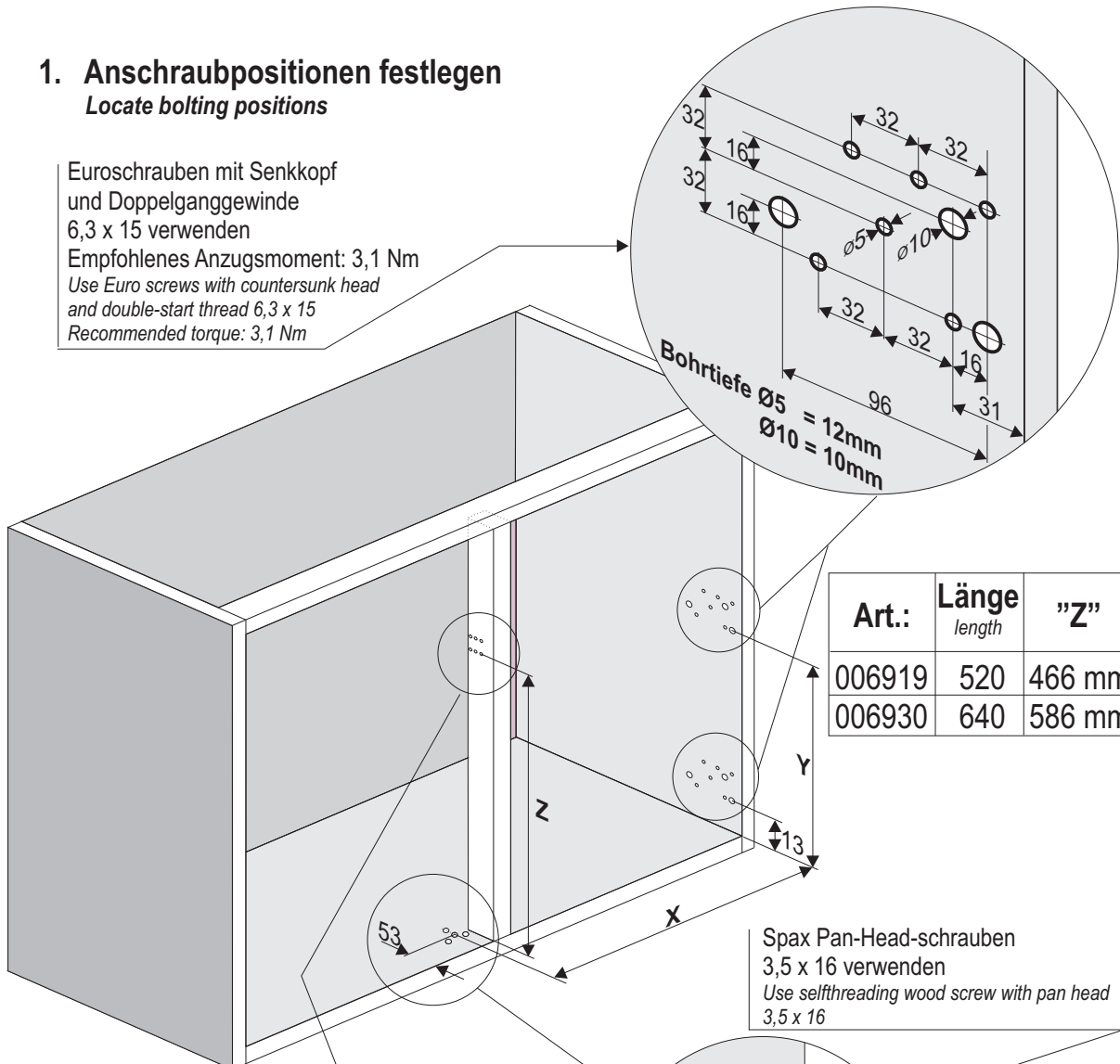

Spax Pan-Head-schrauben 3,5 x 16 verwenden
Use selfthreading wood screw with pan head 3,5 x 16

2 x Euroschrauben mit Senkkopf und Doppelganggewinde 6,3 x 15 oder 2 x Spax- Senkkopfschrauben 4,5 x 16 verwenden
Use 2x Euro screws with countersunk head and double-start thread 6,3 x 15 optional use 2x selfthreading wood screw with countersunk 4,5 x 16

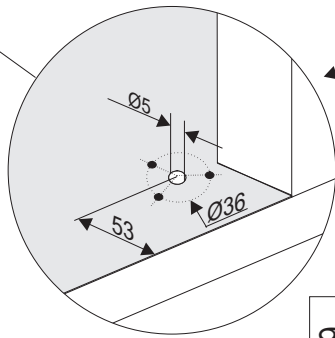
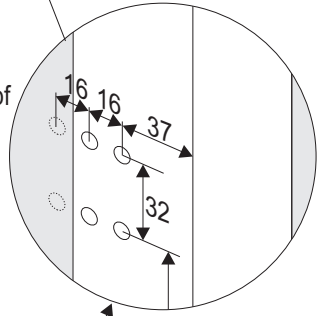

Tür door	"X"
45er	476 mm
50er	526 mm
60er	626 mm

"Y" wahlweise optional	
006919	268 mm
	318 mm
	368 mm
	418 mm
	468 mm
006930	

3 **2. Lager und Scharnier-Montage**
Mounting of bearing and hinge

4

Teile werden lose aufgeschoben
slide parts loose onto axle

5

6

5. Achse fertig montieren *Final mounting of axle*

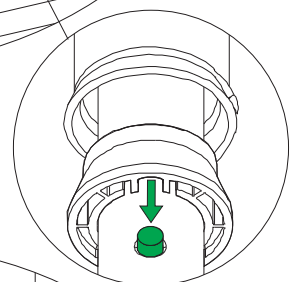
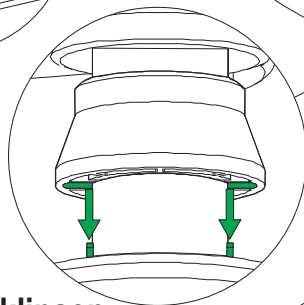
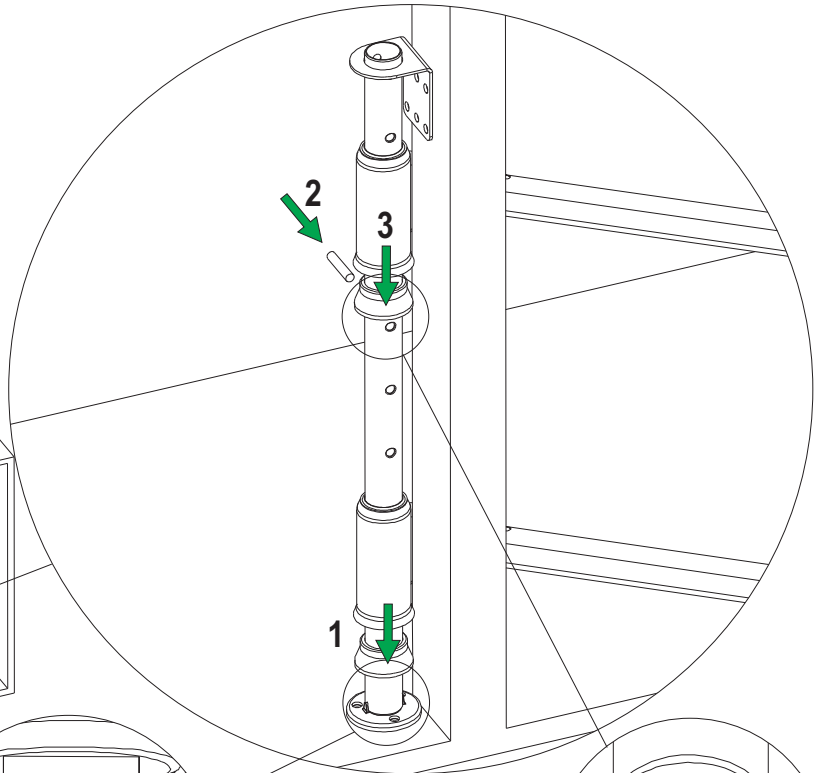
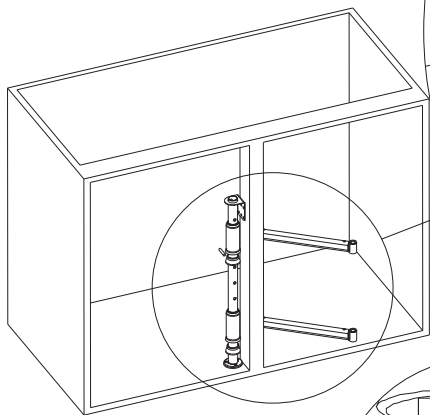
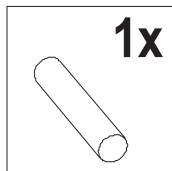

6. Sicherungen einklipsen *Clip on piston ring stops*

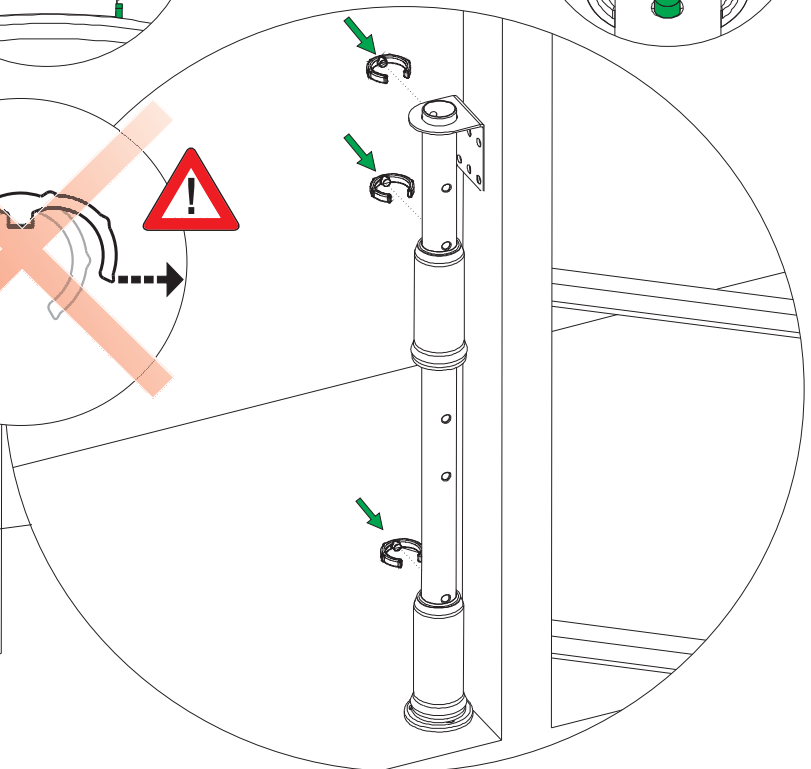
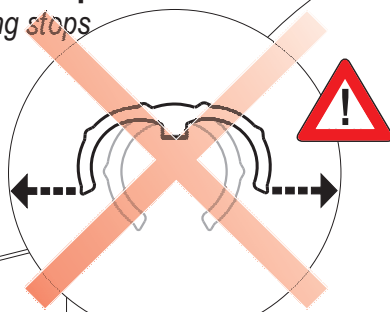
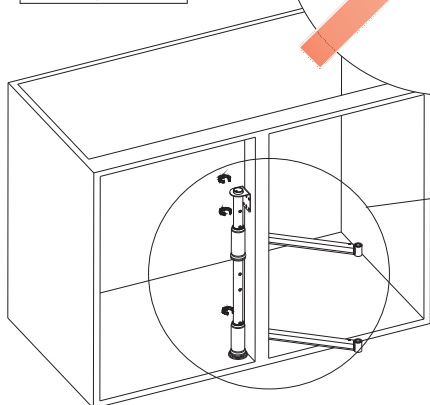
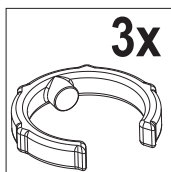

7

7. Ablare montieren *Mounting of shelves*

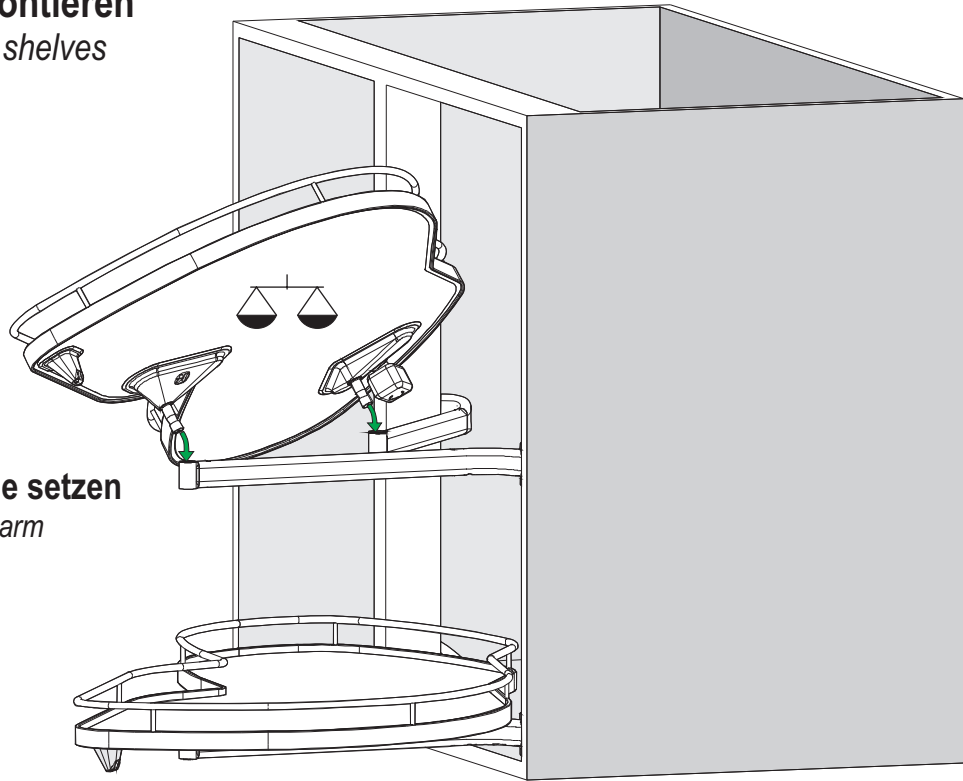
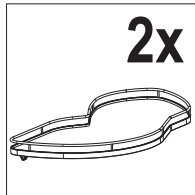

Abtare auf Tragarme setzen
Place shelves on carrier arm

8

**Abtare bis zum Anschlag
eindrücken**
*Press shelves into
dead stop position*



**Bei der Montage
gegenhalten**
*Press from top
and bottom*

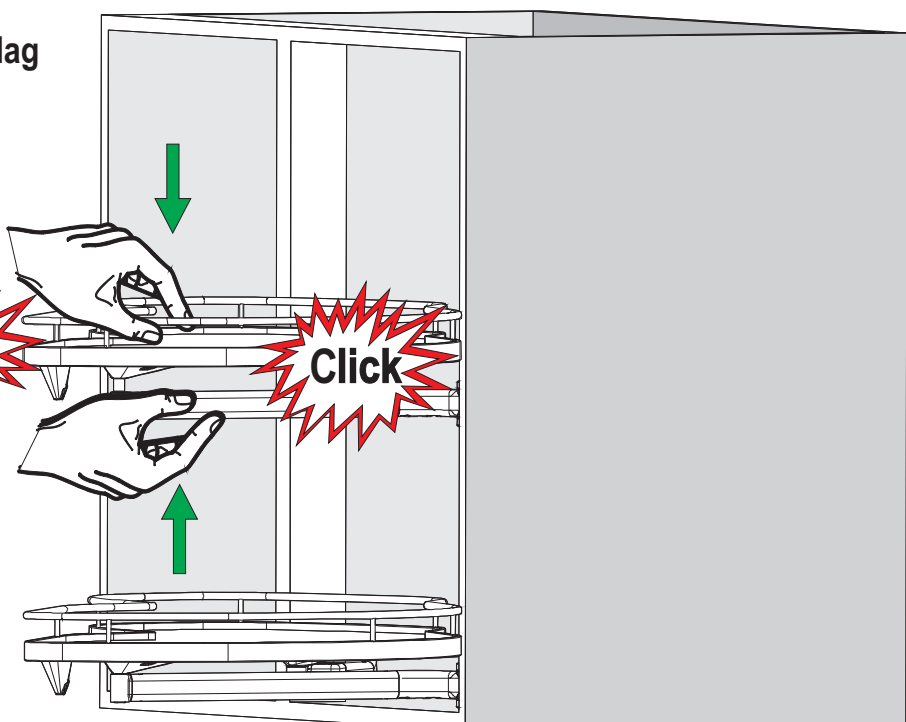

9

Anschlag einstellbar

Opening adjustment

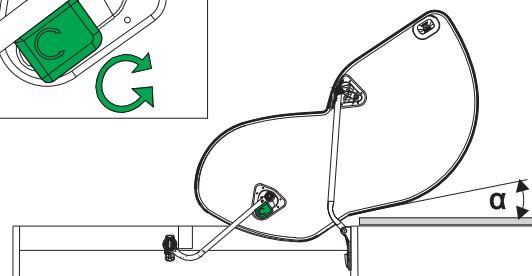
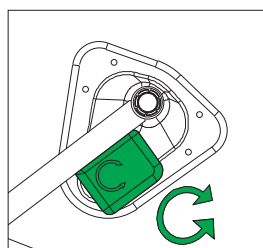
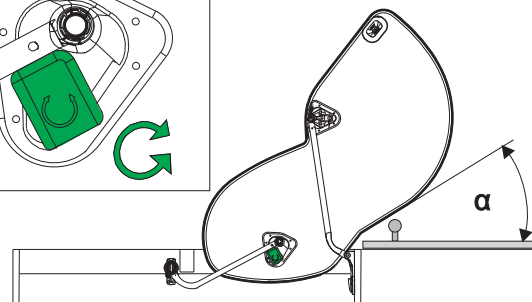
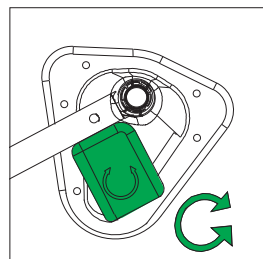
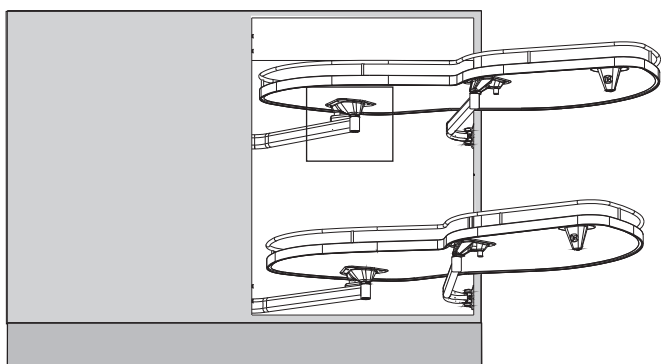

Ausschwenkbewegung über Anschlag begrenzbear

Opening movement adjustable by stop block

10

Demontage

Demounting

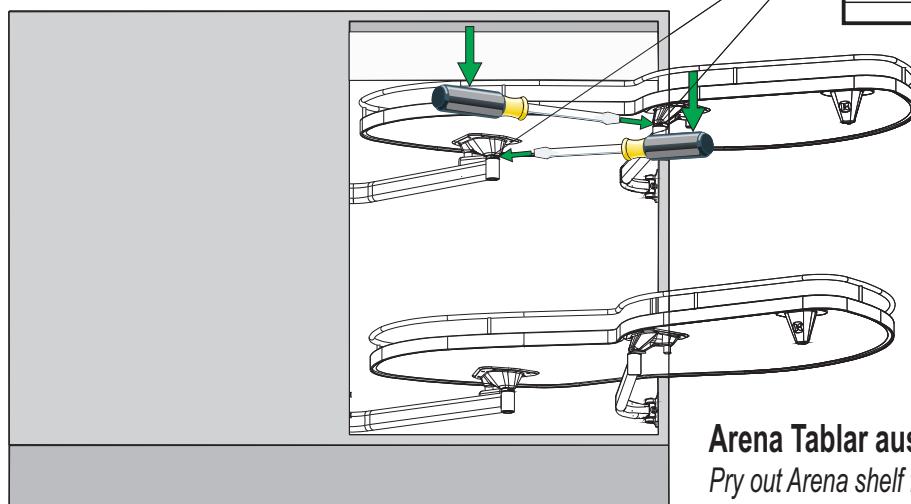
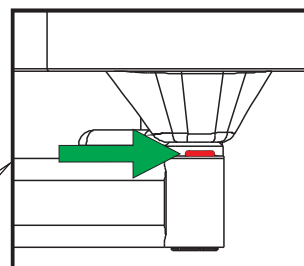
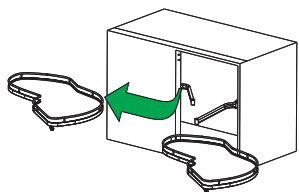

**Bei der Demontage
 gehalten**
*Fix the arms when prying
 out the shelves from
 the carrier arms*

Arena Tablar aus Tragarm hebeln

Pry out Arena shelf from the carrier arms